



428 Jones Boulevard Phone: (610)495-5131  
 Limerick Airport Business Center Fax: (610)495-5134  
 Pottstown, PA 19464 www.watsonmcdaniel.com

# SERIES AVT125

## AIR VENT

### INSTALLATION INSTRUCTIONS

INSTRUCTION PART NO. 2219900

REVISION 2

## INSTALLATION

1. The AVT125 Air Vent should be installed at the highest point of the piping system or equipment where air collects. The air vent can be in any orientation with the outlet piped to a safe place.
2. Before installing the air vent, blow out piping thoroughly to remove loose scale and dirt. Use pipe dope or teflon tape sparingly when attaching the air vent to the pipe. Observe the pressure limitation shown on the label.
3. Discharge piping should be amply sized to avoid excessive back pressures.

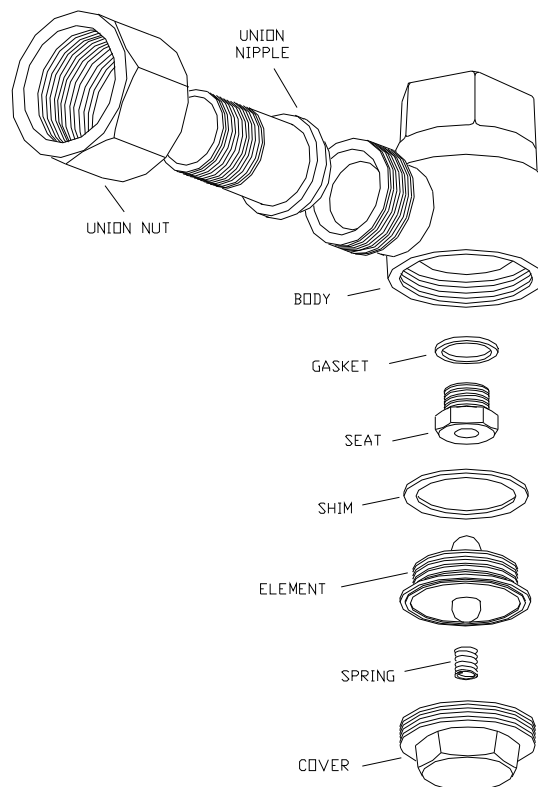
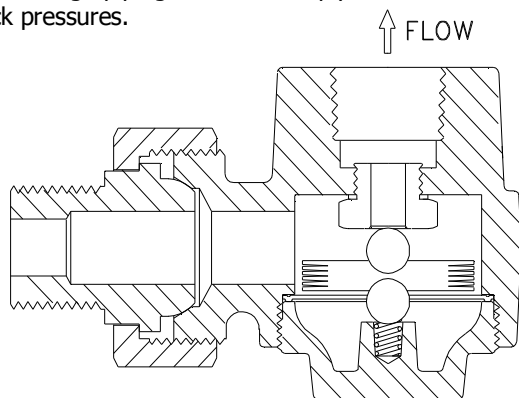

## MAINTENANCE

Close isolation valve and allow the air vent to cool before disassembly to prevent over expansion damage to the bellows. The thermostatic bellows is the only moving part. The ball and seat must be clean for tight shutoff.

At room temperature the bellows should be away from the seat. If defective, the bellows usually remains slightly expanded at room temperature and does not move when placed in boiling water.

When replacing the air vent seat, make sure the gasket is in place and the seat is torqued tight.

## ORDERING SPARE PARTS

Specify the description of the part. Indicate the Size and Model Number which are shown on the name plate.

Typical Specification: Seat for 1/2" AVT125 air vent.

## MAXIMUM OPERATING CONDITIONS

PMO	125 PSIG
TMO	353°F
PMA	125 PSIG up to 450°F
TMA	450°F @ 125 PSIG

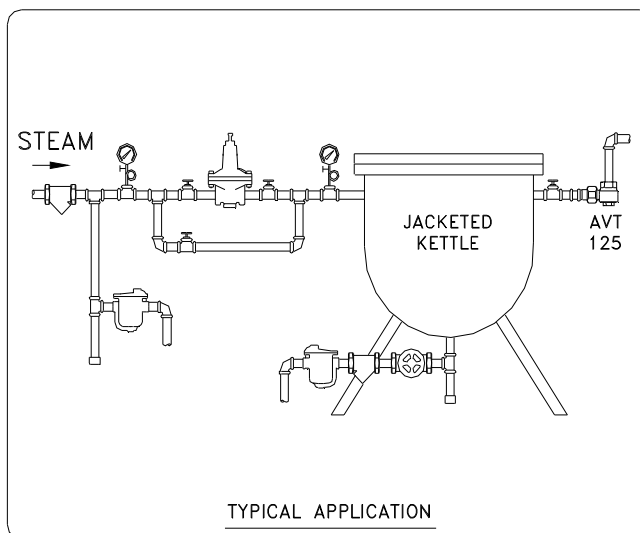

Each Watson McDaniel Company Product is warranted against defects in material and workmanship for one year from date of shipment. This warranty extends to the first retail purchaser only. All defective material must be returned to the person from whom you purchased the Product, transportation prepaid, free of any liens or encumbrances, and if found to be defective will be repaired free of charge or replaced, at the warrantor's or seller's option. If the material is replaced, any replacement will be invoiced in the usual manner and after inspection of alleged defective material an adjustment will be made for depreciation caused by purchaser's use. In no event will Watson McDaniel Company be liable to do more than refund the original contract price. Incidental and consequential damages are excluded, whether under this warranty or otherwise. All implied warranties, including warranties of merchantability and fitness for a particular purpose, are disclaimed and excluded.