

100150 STANDARD SEALS_REVOLVING THREADED FLANGES UNI EN 1092-1



TWO-way ball valve

Drive: Inox lever
Connection: Revolving threaded flanges UNI EN 1092-1
Flow: Full and reduced
Material: Aisi 304L (1.4307) – Aisi 316L (1.4404)
Measure: from DN10 to DN125
Seals: Modified Virgin P.T.F.E.
Operating temperature: -20°C+170°C
Outer finish: Polished

On request:

Antistatic device ATEX II 2 G-D T4 zone 1-21
M.O.C.A. CE 1935/2004
• Seals made of:
PTFE with glass -20°C+170°C
PTFE with carbographite -20°C+180°C
PTFE with inox -20°C+200°C
UHMW High-molecular weight polyethylene -20°C+80°C

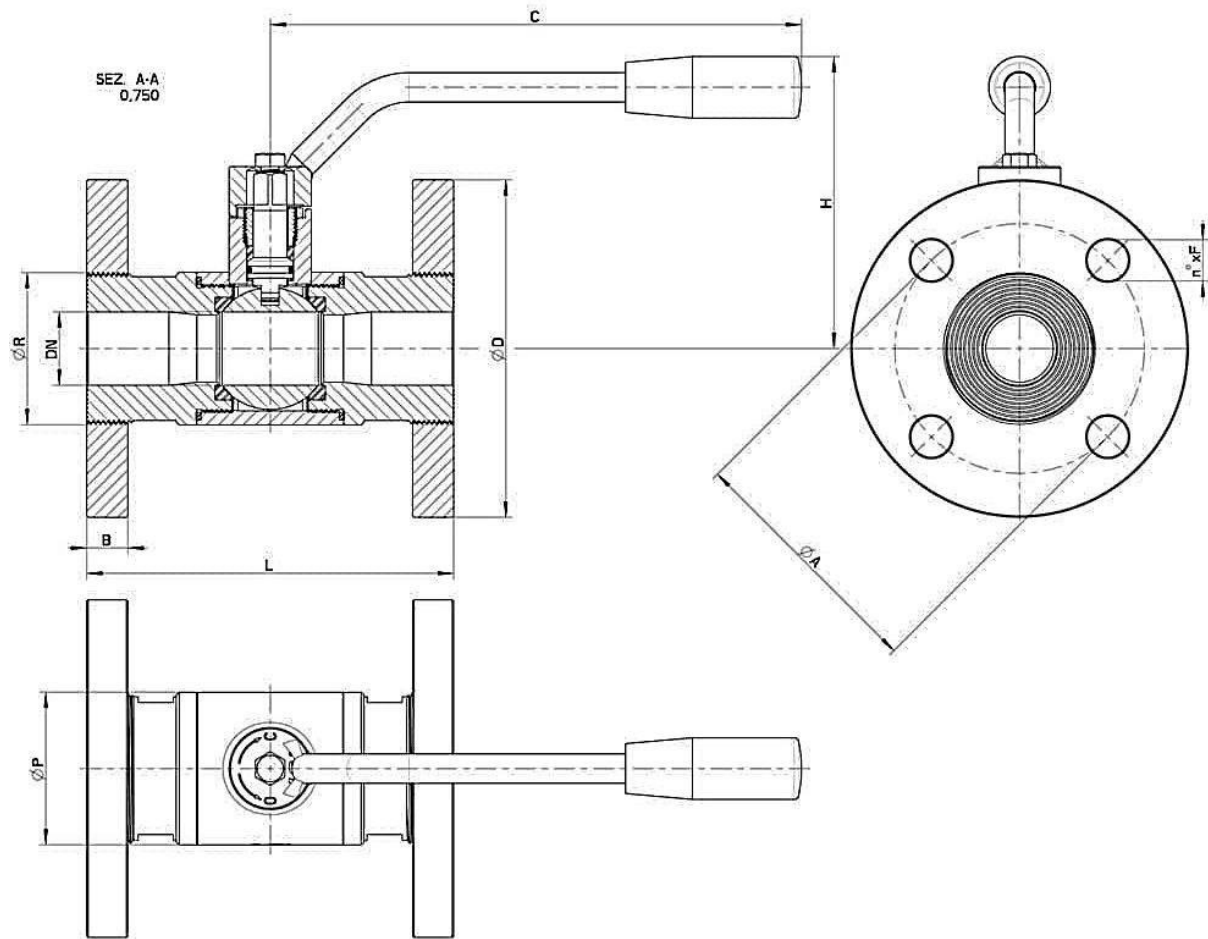

DN	DN	L	C	H	Ø P	D	B	ØR	A	n° x F	PN	Kg
10	10	110	125	70	30	90	12	30	60	4x14	40	1,57
15	15	115	125	75	35	95	12	35	65	4x14	40	1,8
20	20	120	125	80	42	105	14	42	75	4x14	40	2,55
25	25	125	170	100	52	115	14	51	85	4x14	40	3,45
32	32	130	170	110	60	140	16	63	100	4x18	40	5,1
40	40	140	240	120	73	150	16	75	110	4x18	40	6,45
50	50	150	240	130	88	165	18	89	125	4x18	40	8,9
65	65	170	260	145	113	185	18	110	145	4x18	16	13
65	65	170	260	145	113	185	20	110	145	8x18	40	-
80	80	180	300	160	135	200	18	120	160	8x18	16	16,1
80	80	180	300	160	135	200	22	120	160	8x18	40	16,1
100	100	190	330	180	167	220	20	140	180	8x18	16	22,7
100	100	190	330	180	167	235	22	140	190	8x22	25	-
125 (Reduced)	100	200	330	180	167	250	22	153	210	8x18	16	-

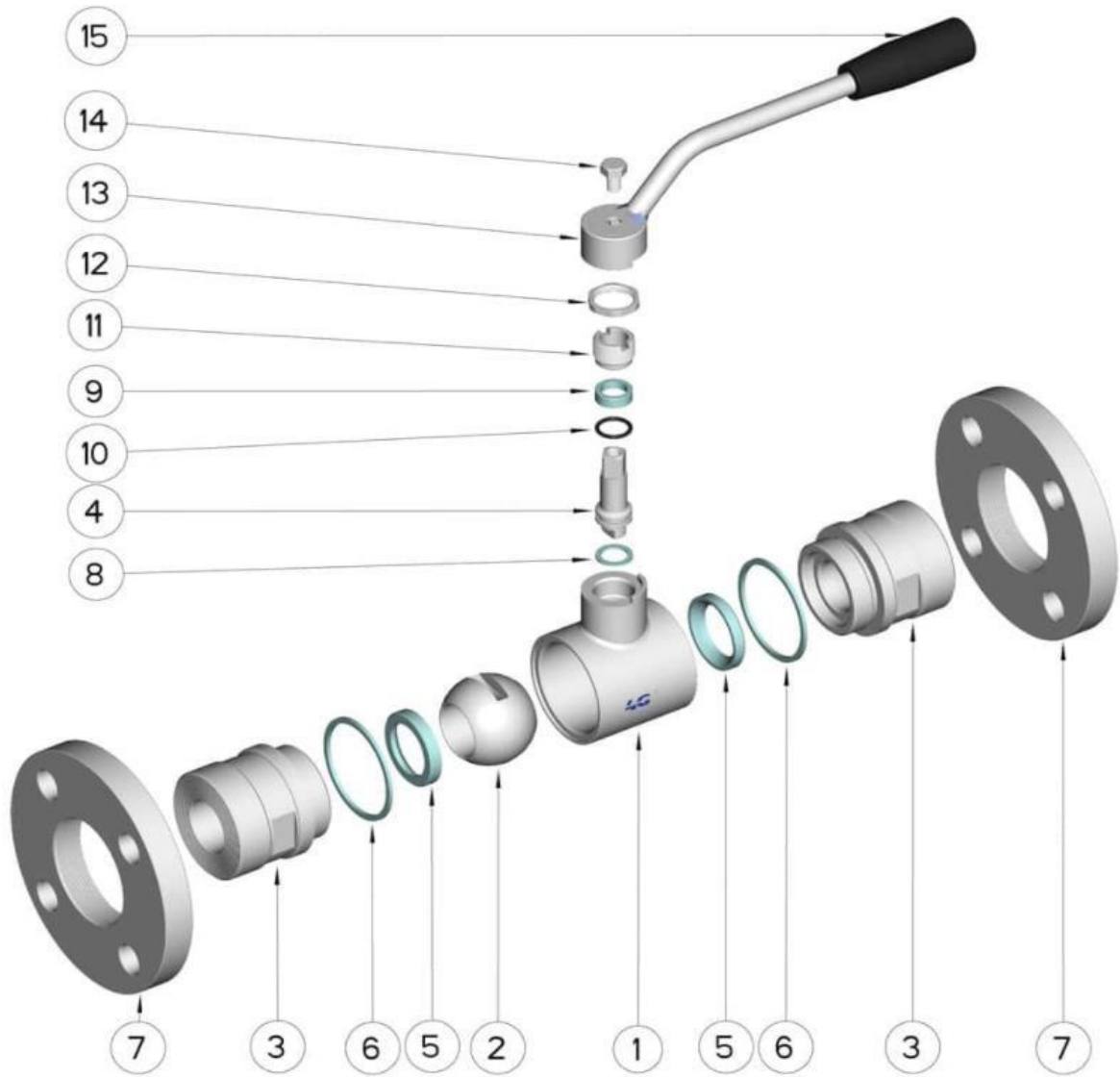

POS.	MATERIAL
1	AISI 304L - 316L
2	AISI 304L - 316L
3	AISI 304L - 316L
4	AISI 304L - 316L
5	PTFE
6	PTFE
7	AISI 304L - 316L
8	PTFE
9	PTFE
10	FKM
11	AISI 304L (303)
12	AISI 304L
13	AISI 304L
14	AISI 304L
15	Resin

